

ILLUSTRATIONS

KIT - CAVI ACCELERATORE A PEDALE - ACCELERATOR CABLES - GASZUGE

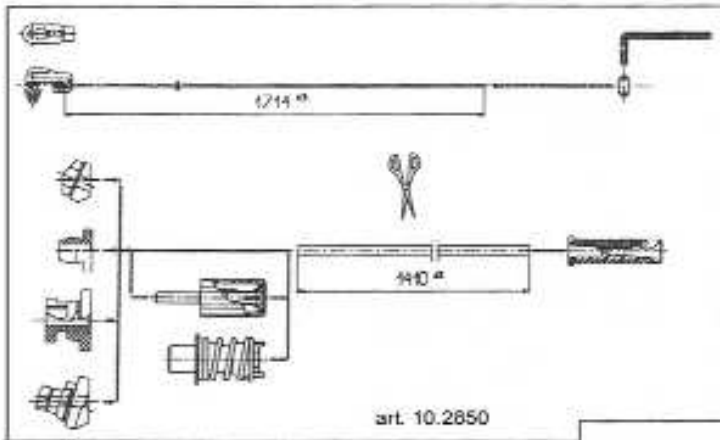

art. 10.2850

KIT ACCELERATORE

CITROEN: AX-Visa-BX-CX-ZX-C15-C3

PEUGEOT: 104-205-309XU-405-

Samba-J9-604DS

ad. 162986

KIT ACCELERATORE

CITROEN: AX-Visa-BX-CX-ZX-C15-C3

PEUGEOT: 104-205-309XU-405-

Samba-J9-604DS

ad. 162986

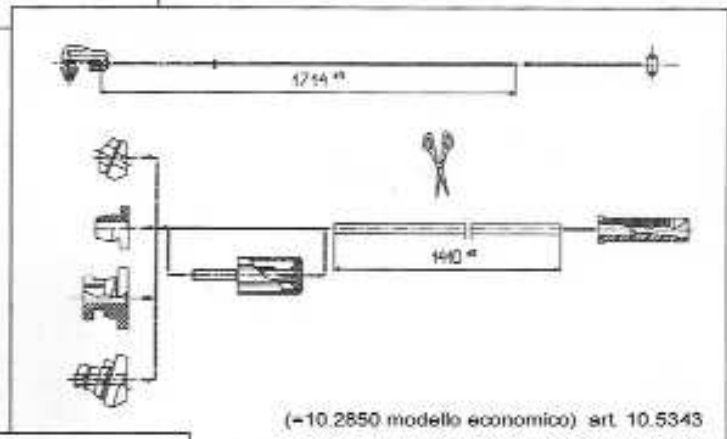

(-10.2850 modello economico) art. 10.5343

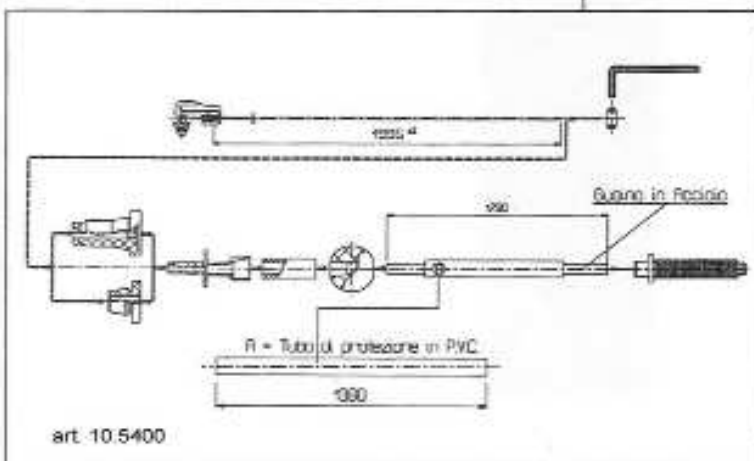

art. 10.5400

KIT ACCELERATORE

PEUGEOT: 306 TU

ad. 1629C5

KIT ACCELERATORE

PEUGEOT: 405

ad. 1629C3

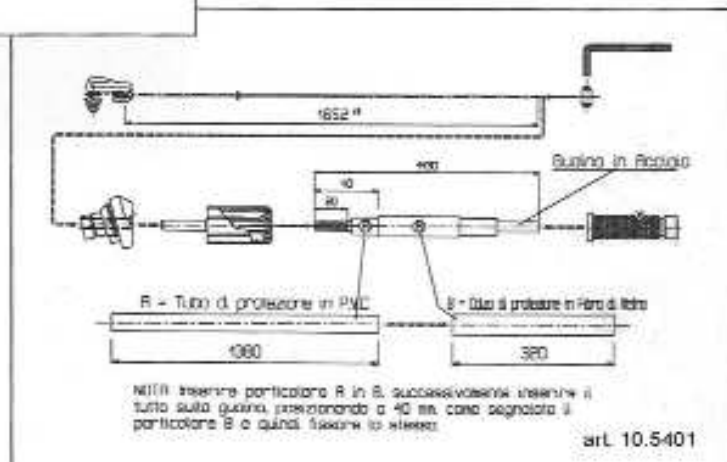

NOTA: inserire particolare R in B, successivamente inserire il tutto sulla guaina, premendo a 40 mm, come segnalato il particolare B e quindi fissare lo stesso.

art. 10.5401

ILLUSTRATIONS

KIT - CAVI ACCELERATORE A PEDALE - ACCELERATOR CABLES - GASZUGE

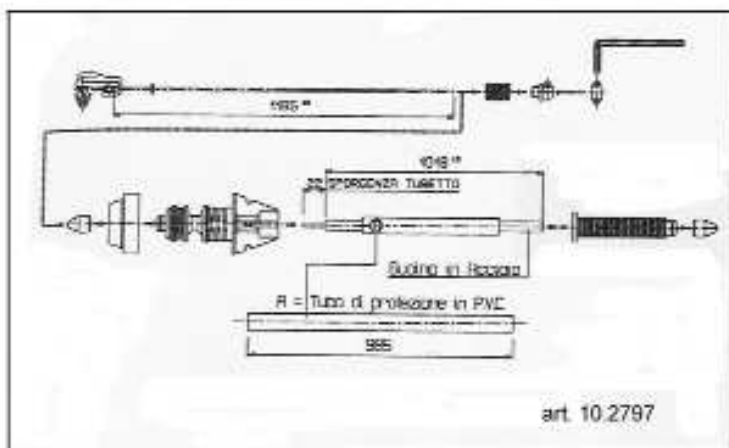

KIT ACCELERATORE
CITROEN: Evasion-Jumpy
PEUGEOT: 806-Expert
FIAT: Ulysse-Scudo
LANCIA: Zeta
ad. 5894946

KIT ACCELERATORE
PEUGEOT-TALBOT
1100-1307-1308-1510
Horizon-Solara

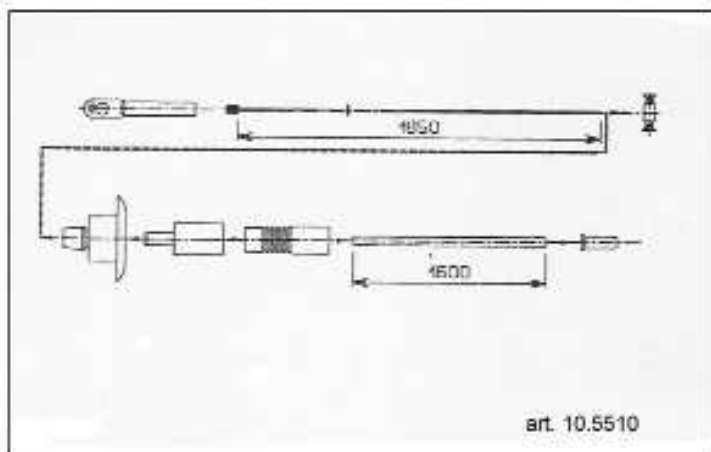
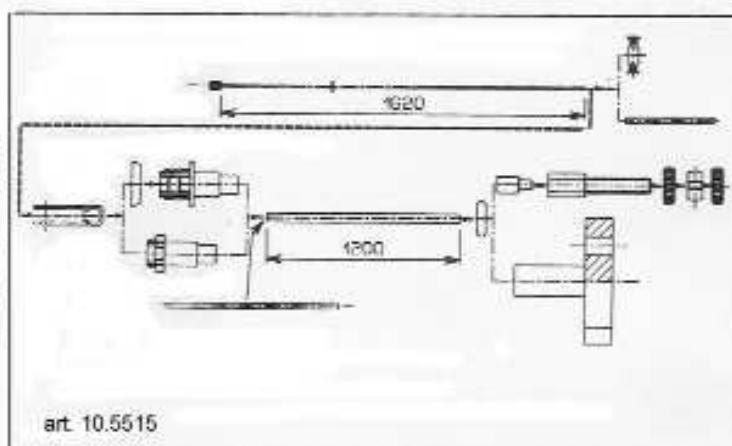

KIT ACCELERATORE
PEUGEOT: 305 tutti tipi

ILLUSTRATIONS

KIT - CAVI ACCELERATORE A PEDALE - ACCELERATOR CABLES - GASZUGE

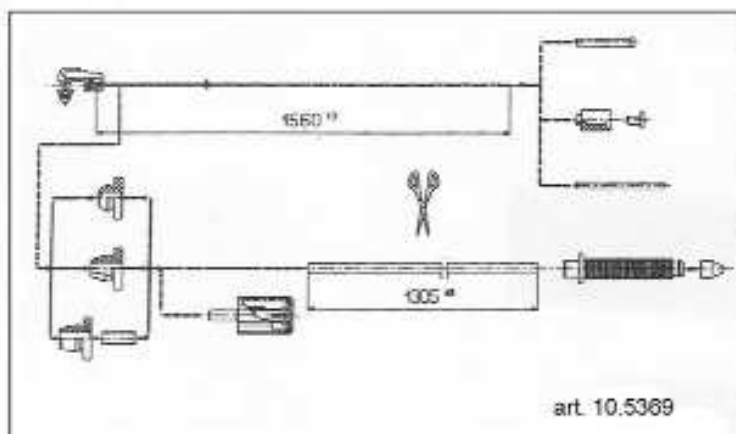

KIT ACCELERATORE

RENAULT: R5-Supercinque- R9-R11
R18-R19-R21-R25-Clio-Fuego-
Espace-Trafic

ad. 7701 349815

KIT ACCELERATORE

RENAULT: Twingo-Clio(-97) - R19-R21
Safrane-Espace-Express

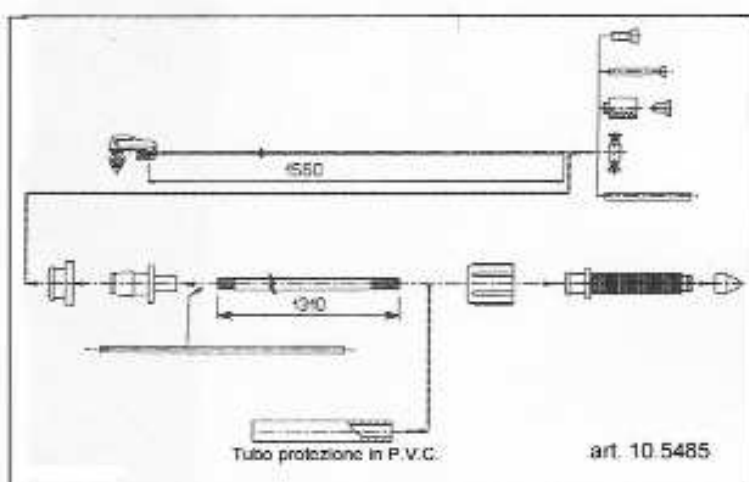

Tubo protezione in P.V.C.

art. 10.5485

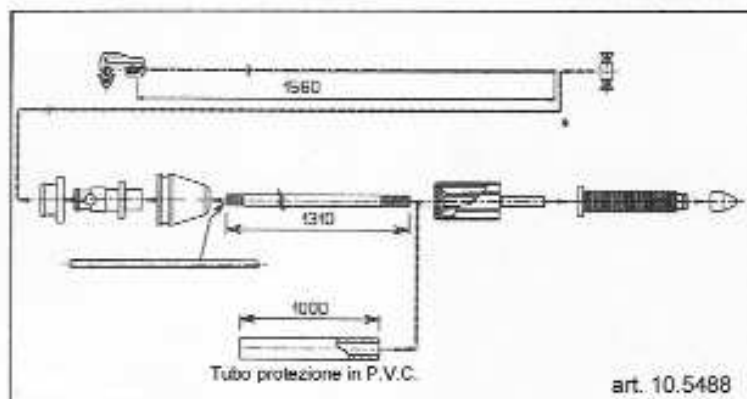

Tubo protezione in P.V.C.

art. 10.5488

KIT ACCELERATORE

RENAULT: Clio-Laguna-Megane- Kangoo

KIT ACCELERATORE

RENAULT: R5 Alpine/Turbo - R12
Trafic-Master

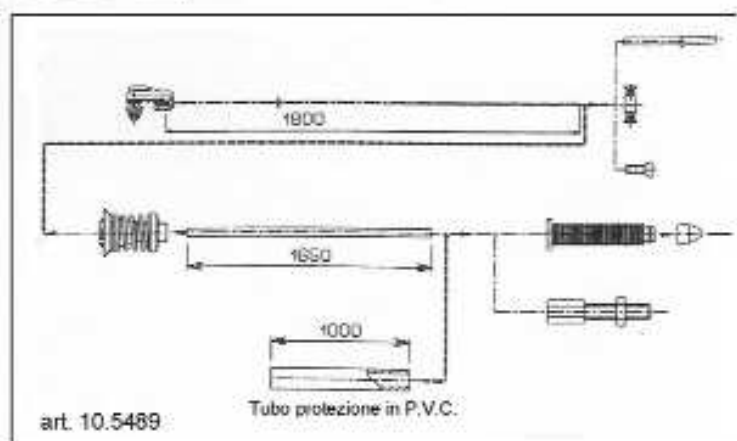

Tubo protezione in P.V.C.

art. 10.5489

ISTRUZIONI PER IL MONTAGGIO - ASSEMBLY INSTRUCTIONS

CAVI DISINNESTO FRIZIONE AUTOREGOLANTI - AUTOADJUST CLUTCH CABLES



1

Montare il comando Frizione con ancora la bussola montata.

Assemble the Friction command in presence of the compass



2

A comando Frizione montato ruotare e sganciare la bussola ad innesto.

Once assembled the friction command turn and unhook the graft compass

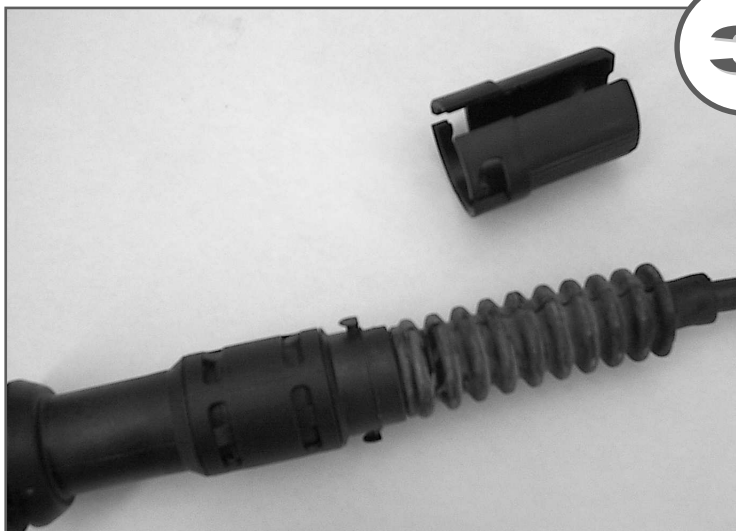

3

Finito e completate le due operazioni precedenti, togliere completamente la bussola dal cavo Frizione

when the two above mentioned operations are made, remove completely the compass from the friction cable.